

RT130

ASTECC

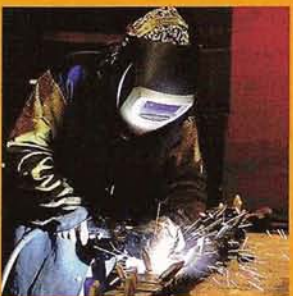

BREAKTHROUGH SOLUTIONS



The Astec line of walk-behind and ride-on utility trenchers, vibratory plows and horizontal directional drills, along with related parts and accessories, offers users a broad choice of underground construction solutions.

The forerunners of the Astec machines were developed by Charles Davis in 1959. Recognized as an industry leader, Davis trenchers were renowned for their innovative designs and rugged reliability. The line was purchased by Case in 1969, and the machines carried the Case-Davis label until the mid 1970s when the Davis name was dropped. Case nurtured the line until 2002 when it was sold to Astec Underground and the machines received the Astec brand.

Astec Underground continues to enhance the line's reputation for performance and durability. Mainstay models like the Maxi-Sneaker and TF300B still have a respected place in the Astec lineup. Innovative walk-behind trenchers like the RT130 and RT160 are quickly joining them. These newly engineered units pay homage to the Astec heritage while confidently demonstrating the company's vision for the future.

Astec products are manufactured at the company's 360,000 square-foot facility in Loudon, Tenn., alongside the company's Trencher line of rock trenchers, surface miners, road miners, and related equipment. Astec has owned the Trencher brand since 1988. The combination of these respected names provides customers with unsurpassed choices to meet their trenching needs.

Astec products are sold and supported through a worldwide network of 47 dealers that operate more than 94 locations. These dealers sell new and used Astec machines, and provide the parts and service to help customers minimize downtime and get needed repair parts.

Visit www.astecunderground.com to learn about the full line of Astec Underground products or to contact the company for more information.

RT130 WALK-BEHIND TRENCHER

ERGONOMIC CONTROLS

SIMPLE, EASY-TO-USE CONTROLS ARE COLOR CODED AND DESIGNED TO ALLOW EVEN NOVICE USERS TO OPERATE THE UNIT WITH CONFIDENCE.

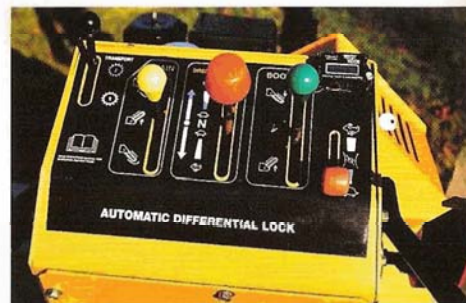

SAFETY FIRST

AN OPERATOR PRESENCE SYSTEM ENSURES THE OPERATOR IS AT THE WORKSTATION WHILE THE UNIT IS IN OPERATION. WHEN THE RED HANDLES ARE RELEASED, THE DIGGING CHAIN STOPS.

FULLY HYDROSTATIC

BOTH GROUND DRIVE AND TRENCHER FEATURE HYDROSTATIC SYSTEMS FOR MAXIMUM EFFICIENCY AND PERFORMANCE. THERE ARE NO MECHANICAL LINKAGE COMPONENTS TO ADJUST.

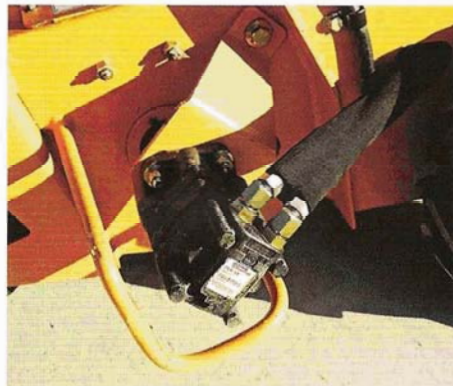

SURE-FOOTED TRACTION

THE RT130'S FEATURES A TRANSAXLE WITH A PATENTED AUTOMATIC DIFFERENTIAL LOCK THAT PROVIDES ADDITIONAL TRACTION IN TOUGH DIGGING CONDITIONS.

RELIABLE POWER

THE RT130 IS POWERED BY A HONDA GX390 SINGLE-CYLINDER, FOUR-STROKE GASOLINE ENGINE. THE 13-HORSEPOWER ENGINE FEATURES AN ELECTRIC AND BACKUP PULL START, THROTTLE, FUEL SHUTOFF, AND OIL ALERT.

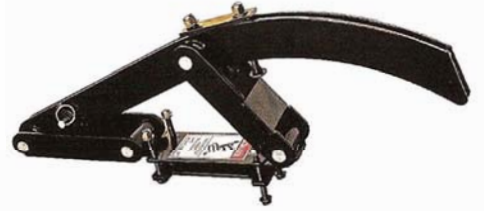

OPTIONAL EQUIPMENT

EQUIP THE RT130 TO MEET YOUR NEEDS WITH OPTIONAL ITEMS LIKE A CRUMB SHOE, EARTHPRO GROUND ENGAGING SYSTEMS DIGGING CHAIN, AND YOUR CHOICE OF A 24-, 30-, OR 36-INCH DIGGING BOOM.



DEPENDABLE DESIGN

TRIPLE BEARING HEADSHAFT DESIGN ENSURES EFFICIENT DIGGING BOOM PIVOT AND SUPPORT.

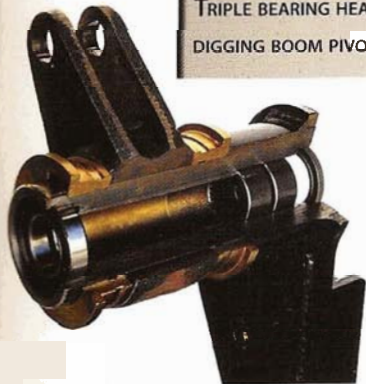

ENGINEERED FOR LONG LIFE

REVERSIBLE DIGGING BOOM PROVIDES FOR EVEN WEAR WHICH EXTENDS THE LIFE OF THE BOOM. THE BOOM IS ALSO EQUIPPED WITH A GREASE FITTING FOR EASY ADJUSTMENT AND QUICK SERVICE.



BREAKTHROUGH SOLUTIONS

RT130 WALK-BEHIND TRENCHER

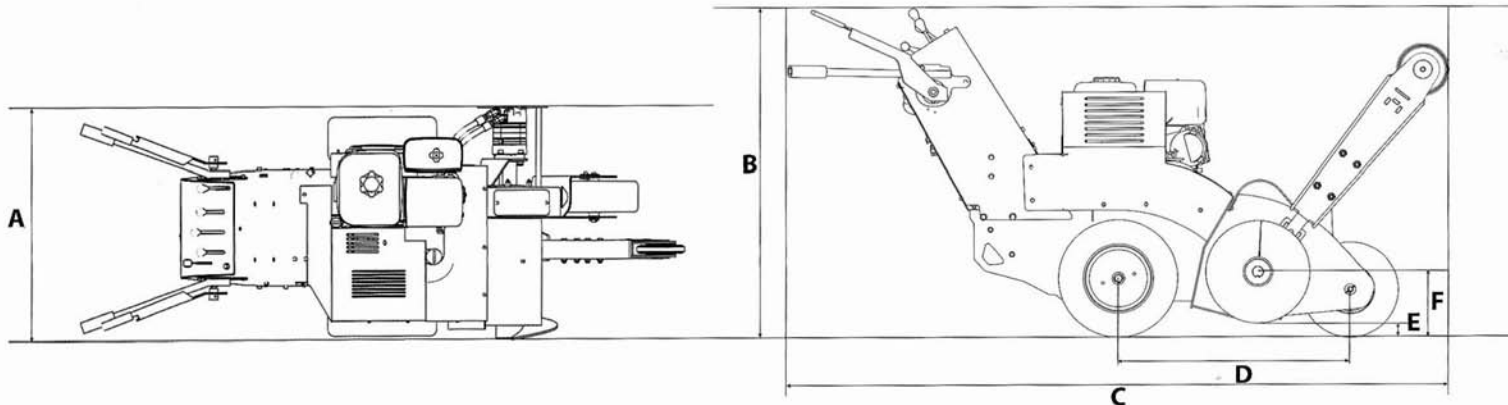

BASIC SPECS

- Honda GX390 single-cylinder, four-stroke gasoline engine, air cooled
Gross: 13 hp (9.7 Kw) @ 3,600 RPM
Electric start with rope start backup, throttle, fuel shut off, oil alert
- Ground drive Hydrostatic pump & motor
with forward and reverse
- Transaxle features auto differential lock
- Trencher Drive Hydraulic gear pump to high-torque gear motor
- Tires Drive: 16x6.50x8
..... Front: 13x5.00x6 single
- Boom lengths .24 in (610 mm), 30 in (762 mm), and 36 in (914 mm)
- Reversible boom with grease fitting adjustment
- Chain widths 4 in (102mm) or 6 in (152.4mm)
- Hydraulic system capacity 5 gal (19 L)
- Wheel connections Keyed hub
- Trencher frame 1-piece
- Cooling system Hydraulic cooler with direct drive fan
- Operating weight (equipped with 24-in [762mm] boom and chain)
..... 903 lbs (410 kg)

ELECTRICAL SYSTEM

Battery 12 volt, 300 cold cranking amps
Starter 12 volt

TRAVEL SPEEDS

Ground speed (forward) 180 fpm (55 m/m)
Ground speed (reverse) 136 fpm (41 m/m)

BASIC MACHINE DIMENSIONS

A. Overall width	34 in (864 mm)
B. Overall height	44.5 in (1,130 mm)
C. Overall length (with 24 in [762mm] boom)	95 in (2,413 mm)
D. Wheel base	31.1 in (787 mm)
E. Ground clearance	2 in (51 mm)
F. Headshaft height	8.9 in (226 mm)
Trench depth, maximum	36 in (1,067mm)
Boom travel, up	50 degrees
Boom travel, down	57 degrees

OTHER STANDARD FEATURES

- Color coded controls
- Hydraulic boom lift
- Operator presence system
- Single auger — 14 in (356 mm) diameter

OPTIONAL EQUIPMENT

- Crumb shoe
- Remote air cleaner
- Hour meter/Tachometer
- EarthPro Ground Engaging Systems digging chain

IMPORTANT: Astec Underground reserves the right to change these specifications without notice and without incurring any obligation relating to such change. This literature has been published for world-wide circulation. Availability of some models and equipment builds vary according to the country in which the equipment is used. The illustrations and text may include optional equipment and accessories and may not include all standard equipment. Your Astec dealer/distributor will be able to give you details of the products and their specifications available in your area.

NOTE: All specifications are stated in accordance with SAE Standards or Recommended Practices, where applicable.

© 2006 ASTEC UNDERGROUND. All Rights Reserved. ASTEC_RT130_12_06